

# MAJOR MOVES

## THE NEW US 31 PLYMOUTH TO SOUTH BEND

Preliminary: as of August '08

### Typical Sections

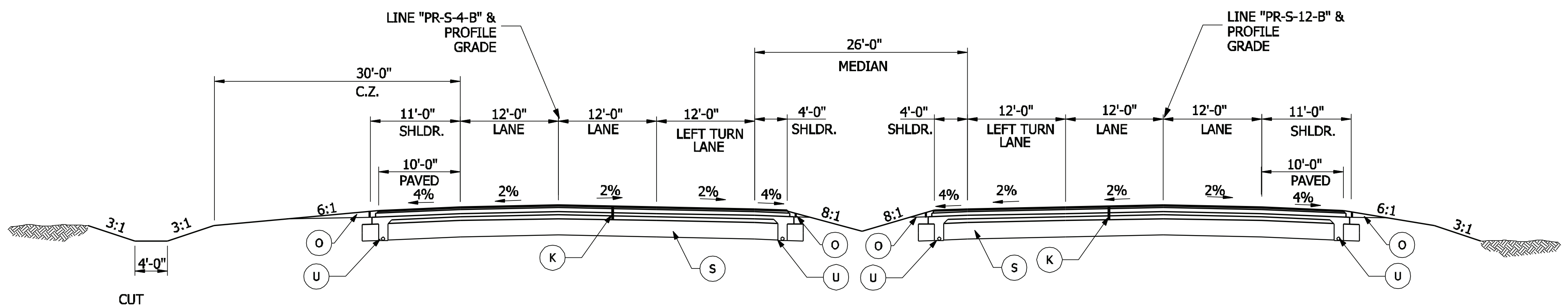

### TYPICAL SECTION

US 6  
(LINE "PR-S-4-B" STA. 39+00.00 TO STA. 49+30.00)  
(LINE "PR-S-12-B" STA. 39+00.00 TO STA. 49+30.00)

Printed on 8/25/08 at 12:38 PM  
 By: E:\mduffy\pdx

TYPICAL SECTION LEGEND		
(K) 165 lb/yd <sup>3</sup> HMA, SURFACE, 5, 76, SURFACE 9.5 mm, SMA ON	(14) INTEGRAL CONCRETE CURB	(21) LONGITUDINAL CONSTRUCTION JOINT
275 lb/yd <sup>3</sup> HMA, 5, 76, INTERMEDIATE 19.0 mm, ON	(15) SUBGRADE TREATMENT TYPE 12" COMPACTED	(22) CONCRETE CENTER CURB, TYPE "C"
605 lb/yd <sup>3</sup> HMA, 5, 64, BASE 25.0 mm, ON	AGG. BASE #53 ON 16" CHEMICAL MODIFICATION	(24) EAR CONSTRUCTION, TYPE "C"
550 lb/yd <sup>3</sup> HMA, 5, 76, INTERMEDIATE OG25.0 mm ON	(16) UNDERDRAIN	(26) SODDING
605 lb/yd <sup>3</sup> HMA, 5, 64, BASE 25.0 mm, ON	(17) 8" COMPACTED AGGREGATE #53 BASE	
12" COMPACTED AGGREGATE, NO 53, BASE	(18) LONGITUDINAL JOINT	
(U) COMPACTED AGGREGATE #53		

RECOMMENDED FOR APPROVAL	DESIGN ENGINEER	DATE
DESIGNED: KJR/GDR	DRAWN: TPH/MPF	
CHECKED: ACD	CHECKED: KJR	

INDIANA DEPARTMENT OF TRANSPORTATION	
TYPICAL CROSS SECTIONS	

HORIZONTAL SCALE 1/4" = 1'-0"	BRIDGE FILE
VERTICAL SCALE	DESIGNATION 0710790
SURVEY BOOK	SHEET 7 of 7
CONTRACT IR-30130	PROJECT